



Factory



Agricultural

■ Features

- The Hi-volume Belt Drive fan unit is specifically designed to ventilate larger buildings, by moving substantial amounts of air at low pressure with minimal energy consumption
- Available in two sizes, 1000mm and 1250mm diameter, each with three phase motors and the option of louvres and guards

■ Construction

- Constructed from galvanised steel with a specially designed stainless steel propeller, these fans are extremely hard wearing and robust in application
- The drive mechanism comprises of a sealed for life maintenance free ball bearings, which means low noise and vibration levels
- Units are supplied fully assembled complete with a standard safety guard on suction side and counter balanced air operated louvre shutter on outlet

■ Motors

- The motors are to be foot mounted totally enclosed metric type to Ip55, with sealed for life bearings and class F insulation, suitable for operating temperatures up to 50°C
- Motors are constructed with finned aluminium casing to provide excellent heat dissipation resulting in a flexible and durable motor

■ Impellers

- Propeller blades are fixed pitch
- The six blades are attached to a mild steel powder coated hub
- The complete assembled propeller unit is balanced to grade G6.3

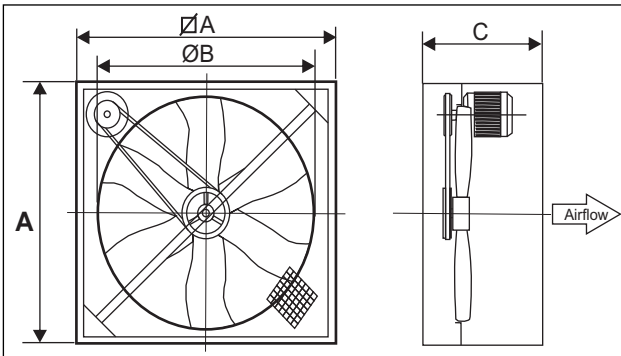

■ DIMENSIONS (mm)

Model	ØA	ØB	C	Descriptions
HV100	1000	995	400	Guards only
HV100L	1000	995	400	Louvre
HV125	1380	1380	400	Guards only
HV125L	1380	1380	400	Louvre

■ TECHNICAL DATA

Model	V	KW	A	Hz	r.p.m.	m ³ /h	dB	Kg
HV100	400	0.75	2	50	505	30000	76	43
HV100L	400	0.75	2	50	505	30000	76	43
HV125	400	1.1	2.8	50	431	42000	78	68
HV125L	400	1.1	2.8	50	431	42000	78	68