



■ Features

- Powerful in-line tubular fan for installation in rigid or flexible ducting
- Is designed for the ventilation of homes or similar premises
- Easy installation

■ Motors

- The motor bearings need no maintenance
- Two-speed motor. The new IMF range of mix flow inline tube fans comes complete with a 2- speed selector switch

■ Wiring Diagram

- Refer to manufacturer's data in package.



Home

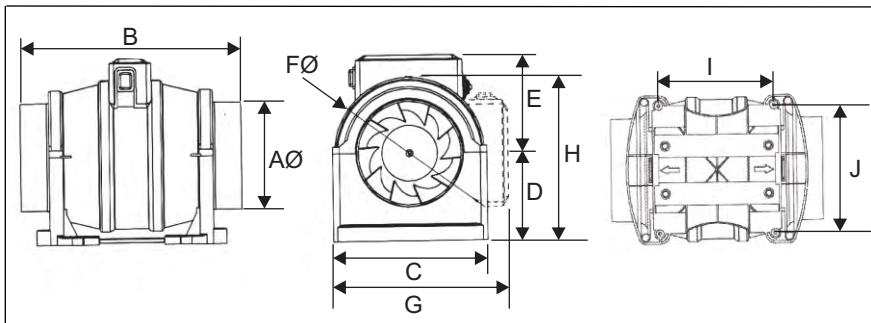

■ WIRING

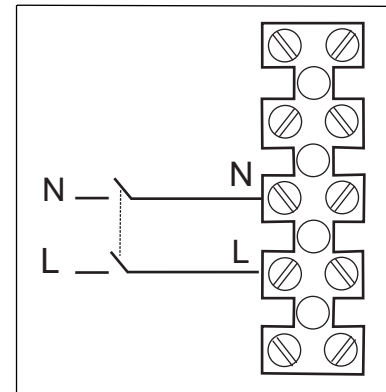

■ DIMENSIONS (mm)

Model	AØ	B	C	D	E	FØ	G	H	I	J
IMF100	97	296	179	104	113	174	202	190	140	154
IMF125	124	256	179	102	113	174	202	190	140	154
IMF150	147	298	194	109	127	195	223	211	182	170
IMF200	198	310	254	129	146	228	272	243	120	236

■ TECHNICAL DATA

Model		r.p.m.	Airflow m ³ /s @ Static Pressure Pa							V	FLC Amps	Input kW	dB(A)@ 3m Inlet	dB(A)@ 3m Outlet	Kg
			0	25	50	75	100	150	200						
IMF100	High	2300	0.067	0.059	0.049	0.038	0.026	0.008		240	0.15	0.034	45	45	2.4
	Low	2000	0.060	0.052	0.042	0.031	0.020	0.004		240	0.15	0.034	44	43	
IMF125	High	2300	0.097	0.089	0.078	0.060	0.033	0.004		240	0.16	0.036	44	45	2.4
	Low	2000	0.085	0.074	0.060	0.041	0.023			240	0.15	0.035	43	43	
IMF150	High	2400	0.162	0.156	0.150	0.143	0.136	0.119	0.098	240	0.30	0.073	55	56	3
	Low	1900	0.124	0.115	0.107	0.099	0.090	0.072	0.038	240	0.26	0.061	50	51	
IMF200	High	2480	0.264	0.257	0.250	0.242	0.233	0.210	0.178	240	0.56	0.125			4
	Low	2266	0.231	0.223	0.215	0.205	0.194	0.166	0.116	240	0.53	0.113			