

# Short Case Axial Fans SCD Series



DUCT  
TUBE  
PROP  
FANS



Factory

## ■ Features

- The Short Case Axial Series 2000 fans is designed for duct mounting. The fans are suitable for a wide range of applications

## ■ Construction

- Galvanised steel casings are rolled and flanged mild steel and hot-dip galvanised as standard
- Impellers are of injection moulded glass reinforced plastic

## ■ Motors

- Type - squirrel cage induction motor
- Electricity supply - 220-240V single or 415V three-phase, 50Hz
- Bearings - Sealed-for-life ball
- Speed controllable using electronic controllers, auto transformers or inverter controllers
- Enclosure IP55

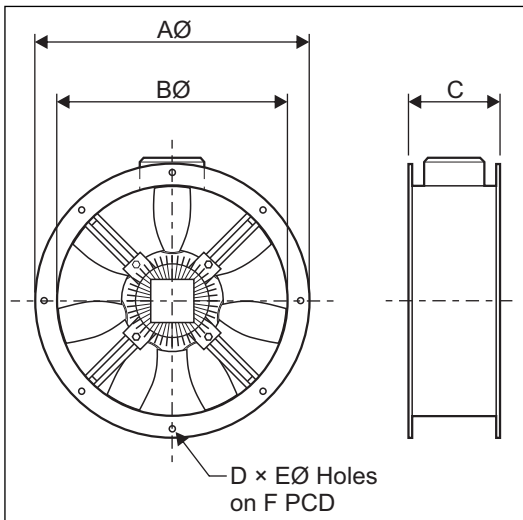

## ■ DIMENSIONS (mm)

Model	AØ	BØ	C	D	EØ	F
250	305	250	180	8	7.0	285
315	382	315	180	8	9.5	355
350	421	350	180	8	9.5	395
400	466	400	190	12	9.5	450
450	515	450	190	12	9.5	487
500	567	500	250	12	9.5	560
560	636	560	250	16	11.5	620
630	709	630	250	16	11.5	690

## ■ TECHNICAL DATA

Model	r.p.m	Airflow m <sup>3</sup> /sec @ Static Pressure Pa.									Motor Electrical Data			dB(A) @ 3m
		0	25	50	75	100	125	150	175	200	FL Amps	SC Amps	Output K	
315/4-1	1320	0.6	0.54	0.42							0.9	1.45	0.09	47
350/4-1	1320	0.9	0.77	0.64	0.49						0.9	1.45	0.09	52
400/4-1-10	1300	1.25	1.24	1.21	1.14	1.09	1	0.8			1.8	3.6	0.25	55
450/6-1-10	850	0.96	0.92	0.86	0.7						1.05	2	0.12	50
450/4-1-10	1300	1.4	1.33	1.25	1.2	0.9	0.8				1.8	3.6	0.25	59
500/6-1-10	860	1.4	1.3	1.2	1.1						1.55	3.5	0.18	54
500/4-1-10	1350	1.96	1.92	1.86	1.8	1.64	1.6	1.56			3.6	10.8	0.55	62
560/6-1-10	875	1.97	1.8	1.72	1.46	1.3					2.2	5.5	0.25	58
560/4-1-10	1350	2.37	2.27	2.18	2.04	2.02	2	1.82			4.9	15	0.75	65
630/6-1-10	850	2.9	2.8	2.65	2.35	2.2					6	12.6	0.55	59