

Supply Valve VST Series

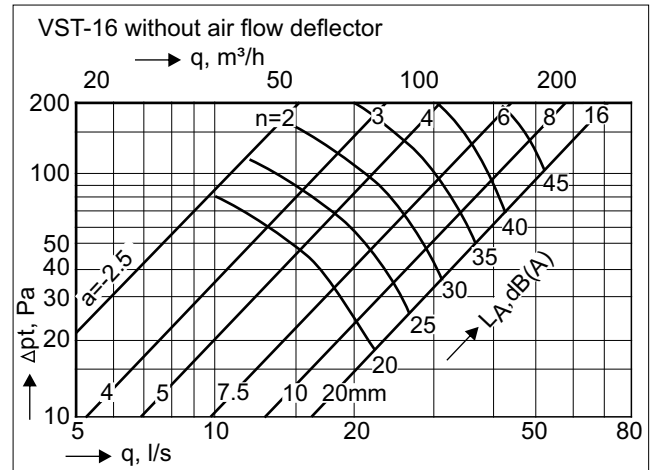
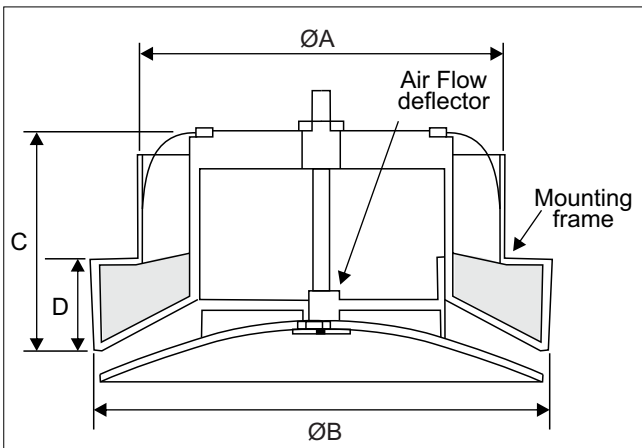
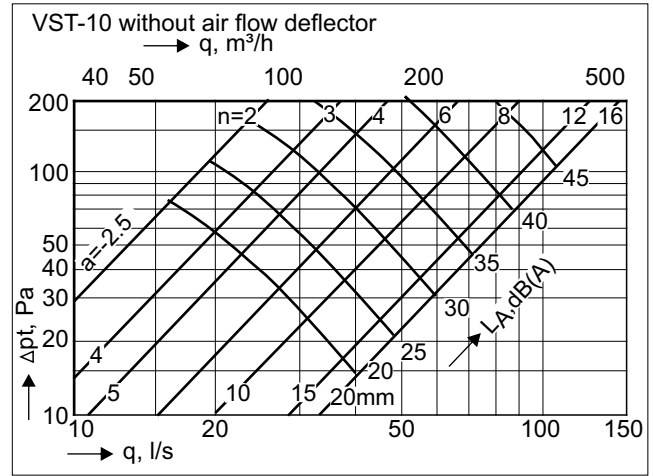

■ DIMENSIONS (mm)

Model	AØ	BØ	C	D	Kg
10	100	150	66	30	0.14
12	125	175	71	35	0.21
16	160	200	76	40	0.27

■ SOUND POWER LEVEL Hz, CORRECTION OF SOUND LEVEL IN DB AT

Model	63	125	250	500	1000	2000	4000	8000
10	-3	3	7	4	-5	-13	-19	-20
12	-1	2	5	3	-1	-10	-19	-20
16	0	5	5	3	-4	-11	-20	-20

8

■ SOUND ATTENUATION Hz, CORRECTION OF SOUND LEVEL IN DB AT

Model	63	125	250	500	1000	2000	4000	8000
10	22	19	13	9	6	7	7	7
12	20	17	12	8	6	7	7	7
16	19	15	11	8	7	8	7	7